

# Schaerer Coffee Joy

Small, smart and fully automatic

 **schaerer**

Coffee comes to life





## Superior class in a compact design

---

**Superb quality at the press of a button, an elegant compact design and simple operation: Schaerer Coffee Joy is a delight for smaller applications that call for 30 to 50 cups a day.**

### **The small professional**

With a width of only 30.5 cm, Schaerer Coffee Joy is the smallest in our range of fully automatic coffee machines. It is ideal for applications such as bars, offices and meeting rooms. When it comes to coffee quality, beverage selection and operating comfort, it matches the capabilities of our larger high-performance coffee machines. Like these, it contains the latest Schaerer coffee machine technology and a fully automatic milk system.

### **Six different beverages just a touch away**

Whether your preference is espresso, café crème, cappuccino or latte macchiato: just a small tap on the touch panel and Schaerer Coffee Joy guarantees you great coffee enjoyment. In addition, hot milk, milk foam or hot water can be dispensed by a simple touch. Thanks to the “double function” buttons and the double outlet, Schaerer Coffee Joy can simultaneously prepare two beverages. The “barista” button gives you the freedom individually to set the coffee strength.

### **Impeccably hygienic**

With the Schaerer Coffee Joy you can always count on Schaerer’s hygiene standards. They fulfil all international regulations pertaining to milk processing and milk system cleaning. Nothing will detract from your enjoyment of the perfect cup of coffee.



## Schaerer Coffee Joy at a glance

### The advantages

- Superb coffee quality
- Six beverages at a touch
- Simple operation
- Easy and rapid cleaning
- Elegant, compact design
- Hourly/daily output of 30 – 50 cups (depending on beverage)

### Equipment

- User-guided liquid crystal display in 10 languages
- Barista button for individually setting the coffee strength
- Integrated milk foamer for creamy milk foam
- Height-adjustable double outlet
- Inlet for ground coffee (e.g. caffeine-free)
- Grinder with precision grinding discs
- Modern brewing technology
- Integrated water tank
- Cup counter
- Passively heated cup storage

### Cleaning

- Automatic cleaning and decalcification programme
- Fulfils HACCP-compliant hygienic regulations
- Simple removal of the brewing unit for cleaning
- "Easy Clean" milk cleaning system

### Options

- Bean hopper extension (total capacity 650 g)
- External cooling unit for milk

### Technical data

Dimensions (W/H/D):	305/400/443 mm
Weight:	Approx. 16 kg
Nominal power:	2.0 – 2.2 kW
Power supply:	1/N/PE ~50/60 Hz; 220 – 240 V
Height-adjustable outlet:	67 – 141 mm
Water tank:	2.2 l
Bean hopper (standard):	250 g
Serial interface:	PC link for Configtool

## Dimensions

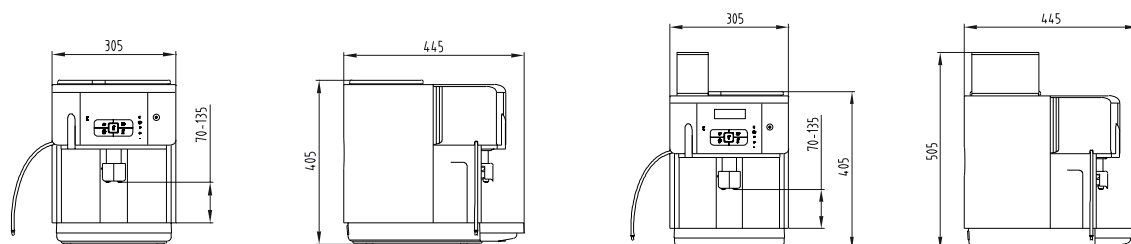

Schaerer Coffee Joy

Schaerer Coffee Joy  
with bean hopper extension

**Headquarters****Schaerer Ltd.**

Allmendweg 8  
 4528 Zuchwil  
 Switzerland  
 T + 41 (0)32 681 62 00  
 F + 41 (0)32 681 62 42  
 info@schaerer.com

**Subsidiaries****Schaerer USA Corporation**

2900 Orange Ave., Suite 102  
 Signal Hill, CA 90755  
 USA  
 T + 1 562 989 30 04  
 F + 1 562 989 30 75  
 info@schaererusa.com

**Schaerer Deutschland GmbH**

Siechenlach 1  
 89173 Lonsee-Urspring  
 Germany  
 T + 49 (0)73 36 95 25 - 0  
 F + 49 (0)73 36 95 25 - 100  
 info@schaerer-gmbh.de  
 www.schaerer-gmbh.de

**Schaerer Benelux – Guy van Bogaert**

Boomsesteenweg 608  
 2610 Wilrijk – Antwerpen  
 Belgium  
 T + 32 (0)3 828 11 28  
 F + 32 (0)3 820 90 90  
 info@schaerer.be

[www.schaerer.com](http://www.schaerer.com)



## Geschätzte Partner

### Kühleinheiten zu Schaerer Coffee Vito und Schaerer Coffee Art

Die Schaerer AG kann Ihnen weitere Kühlgeräte anbieten, um Ihre Bedürfnisse möglichst optimal abzudecken.

#### 1. Schaerer Coffee Vito

##### 1.1 Unterstellkühleinheit



Die Unterstellkühleinheit kann direkt unter die Kaffeemaschine gestellt werden. Die Milchschlauchführung wird durch die Tropfschale geleitet. Der Milchbehälter hat ein Fassungsvermögen von ca. 9.5 Liter.

Nennleistung	0.004 kW
Netzanschluss	230 V
Breite	345 mm
Höhe	296 mm
Tiefe	533 mm
Leergewicht	22 kg

Die Unterstellkühleinheit ist unter Berücksichtigung der üblichen Lieferzeiten ab sofort bestellbar.  
Art Nr. 040110      Masterpreis in CHF 3'280

##### 1.2 Beistellkühleinheit und Becherspender



Die Beistellkühleinheit kann direkt neben die Kaffeemaschine gestellt werden. Der Milchbehälter hat ein Fassungsvermögen von ca. 6.5 Liter.

Nennleistung	0.09 kW
Netzanschluss	230 V
Breite	230 mm
Höhe	350 mm
Tiefe	517 mm
Leergewicht	16.5 kg

Die Beistellkühleinheit ist unter Berücksichtigung der üblichen Lieferzeiten ab sofort bestellbar.  
Art Nr. 040125      Masterpreis in CHF 2'460

Diese Beistellkühleinheit ist auch abschliessbar bestellbar.  
Art Nr. 040130      Masterpreis in CHF 2'811

Der passende Becherspender dazu können Sie wie folgt bestellen:  
Art Nr. 03.9199.0001      Masterpreis in CHF 730



## Kühleinheiten zu Schaerer Coffee Vito und Schaerer Coffee Art

### 1.3 Beistellkühleinheit



Die Beistellkühleinheit kann direkt neben die Kaffeemaschine gestellt werden. Für die passende Milchschauchführung ist ein Durchbruch vorgesehen. Der Milchbehälter hat ein Fassungsvermögen von 4 Liter.

Nennleistung	0.09 kW
Netzanschluss	230 V
Breite	185 mm
Höhe	485 mm
Tiefe	387 mm
Leergewicht	12 kg

Die Unterstellkühleinheit ist unter Berücksichtigung der üblichen Lieferzeiten ab KW 41 bestellbar.  
 Art Nr. 060751                      Masterpreis in CHF 1'625

## 2. Schaerer Coffee Art

### 2.1 Beistellkühleinheit für Milk Smart



Die Beistellkühleinheit (siehe Beistellkühleinheit unter Punkt 1.3) können Sie auch passend neben die Schaerer Coffee Art stellen. Die entsprechende Schlauchführung ist vorhanden. Sie können für Bestellungen dieselbe Artikelnummer verwenden.

# The first choice For connoisseurs and calculators

## Schaerer Coffee Prime

- ▶ **Gourmet beverages at the press of a button**
- ▶ **Perfect for self-service**
- ▶ **Cost saving and environmentally friendly to operate**
- ▶ **Minimal cleaning and maintenance**
- ▶ **Successively expandable**



# Make it your way

Anyone who aims for high quality but not for a high investment will find Schaerer Coffee Prime to be the machine of choice: it can be readily expanded to accommodate growing needs.



## Successively expandable

Do you want to keep your initial investment low and see how your coffee business develops before you invest more? Then Schaerer Coffee Prime is the perfect solution for you.

Thanks to its **modular design** and various degrees of expansion, this coffee machine can be **conveniently retrofitted on location** to meet your growing needs. That's good for your budget and ensures that your investment remains sustainable and secure.



## Cost saving and environmentally friendly to operate

Schaerer Coffee Prime spares your wallet and the environment:

- **Compact environmentally friendly disposable concept for the milk system.** Components in contact with milk are simply exchanged, eliminating the need for chemical cleaning products.
- **Minimised power consumption** due to compact machine components.
- **Fully insulated boiler** with power-saving heating technology.
- **Power consumption of less than 0.5 watt** in standby mode.
- **PowerSave mode** for lower current consumption during operation.

Schaerer Coffee Prime for offices, cafés, universities, hospitals, sports centres, cultural events, workshops, filling stations, car dealerships...



## Gourmet beverages at the press of a button

Schaerer Coffee Prime produces up to 40 freely programmable beverages containing coffee, fresh milk, milk powder, Choco powder, instant products and hot water – beverages of the highest quality at the press of a button.

The technology behind it:

- **Separate preparation systems** and outlets prevent contamination with other beverages.
- **Combined operation** with fresh milk and milk powder – even lactose-free beverages can be offered.
- **More beverage variety** thanks to the powder system for 1 or 2 powder types (for example, milk powder, Choco powder, instant products).
- **Professional fine adjustment of all beverage parameters.**
- **The transparent foamer head** makes hygiene monitoring easier – a prerequisite for impeccable milk quality.
- **Consistent milk foam quality** thanks to air pump technology.
- In models with two grinders, **roasted coffee can be drawn and mixed** from both grinders.





# Simple, secure and reliable

Schaerer Coffee Prime puts user-friendliness first when it comes to operation, cleaning and maintenance. These are your advantages:



## Perfect for self-service

- Simple operation via the **7" touch screen user panel** TouchIT (in two versions: for self-service and for operation by personnel).
- **Colour-guided operation** for cleaning and exchanging disposable parts.
- **Display with customised button layout** and advertising messages, which also appear while beverages are being prepared.
- **Easy to commission** due to Demo Mode on the display.
- **Code-protected access** (Code Safe) for bean hopper, powder system, grounds container and water tank.
- **Display messages** for "Fill water tank", "Fill bean hopper" and "Empty grounds container".



## Minimal cleaning and maintenance

- **No cleaning required** for the milk system (environmentally friendly disposable concept with NcFoamer, non-cleaning Foamer).
- **Automatic coffee system cleaning programme** backed by animations.
- Side cooling unit with **hygienic standards compliant with the HACCP analysis process.**
- **The removal of just one screw** provides access to all components requiring maintenance (Single-screw Access).



# Optional accessories and configurations



## Optional accessories and product details



1 Disposable concept for the milk system with NcFoamer



2 Up to 2 grinders with bean hoppers



3 2 powder containers

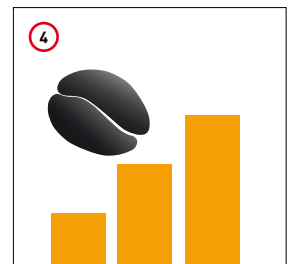

4 Barista key



5 7" TouchIT



6 Aquachange



7 Pivoting cup platform and drip grid



8 Under-counter grounds disposal

## Configuration

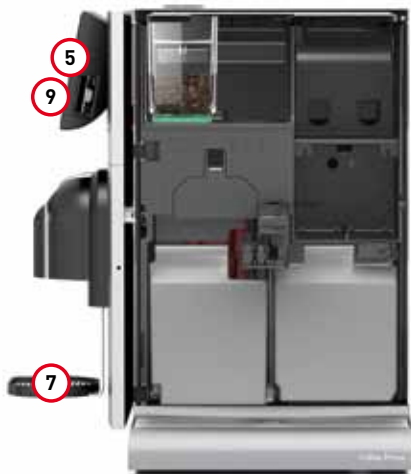

Standard

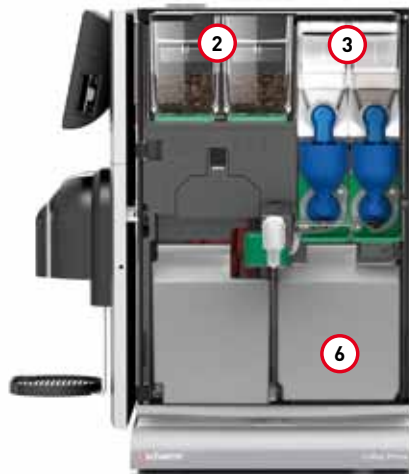

- 2nd grinder
- 2 powder containers
- Disposable concept for the milk system with NcFoamer

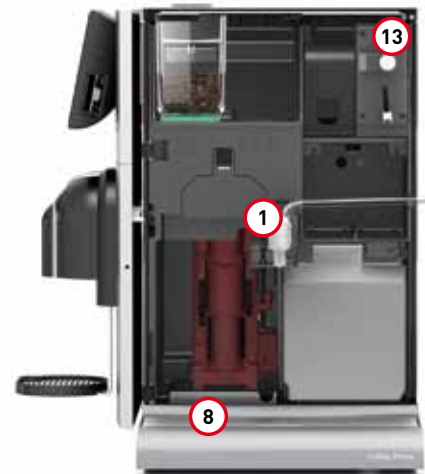

- Integrated coin tester
- Disposable concept for the milk system with NcFoamer
- Under-counter grounds disposal
- Side cooling unit



Code Safe



Side cooling unit with compressor



Cup dispenser



Coin changer attachment



Integrated coin tester



0.5 watt standby

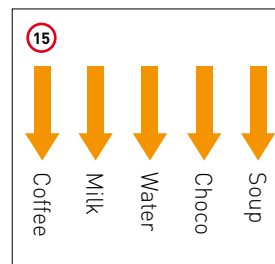

Separate preparation systems and outlets prevent contamination



Combined fresh milk and milk powder supply

# Equipment and options



## Standard equipment

- **One grinder with bean hopper** for 700 grams of beans (with LED lighting).
- **7" touch screen user panel** TouchIT.
- **Aquachange:** conversion from drinking water tank (5.2 litres) to mains water supply by in-house technician possible.
- **Pivoting cup platform.**
- **Drip grid of nickel-chromium steel**, dishwasher-proof.
- **Grounds container** for approx. 35 coffee grounds cakes.
- **Barista key** for setting flavour intensity.
- **Total and separate beverage counters.**



## Options

- **2nd grinder** with bean hopper.
- **Side cooling unit** with capacity for two gallon containers or one 8-litre container (hygiene standard compliant with HACCP concept).
- **Space-saving milk storage** in the under-counter cooling unit or in the under-machine cooling unit, each with a 9-litre capacity.
- **Centre Milk:** a cooling unit for two coffee machines.
- **Powder system** for one or two powder types (2x1 litre, separate preparation systems).
- **Under-counter grounds disposal** (without requiring machine modification).
- **Cup dispenser** for 3 different paper cup sizes (diameter in mm 60-74 / 75-82 / 83-90).
- **Integrated coin tester**, can be connected separately (retrofitting also possible).
- **Conventional payment systems** according to the MDB standard (can simply be connected to the coffee machine).



You can trust in Schaerer



### Swiss made



**Swiss Engineering:** Schaerer Coffee Prime was developed entirely by Schaerer in Switzerland.

**Swiss Manufacturing:** Schaerer Coffee Prime is produced by Schaerer in Switzerland.



**Swiss Services:** Schaerer Coffee Prime is accompanied by a comprehensive service package (training, service and support) from Switzerland.

## Technical data

Category	Equipment and options	Coffee Prime
<b>Output rate and beverages</b>	Beverage output per hour/day (coffee, espresso)	Up to 60
	Ristretto	x
	Espresso	x
	Coffee	x
	Milk coffee / latte	x
	Cappuccino	x
	Latte macchiato	x
	Moccaccino	x
	Hot milk	x
	Milk foam	x
	Hot water	x
	Instant products (eg. tea, soup)	x
	<b>Dispensing procedure</b>	Self-service mode
Number of beverages possible (programmable)		40
<b>Grinders</b>	1 grinder	s
	2 grinders	o
<b>Boiler and brewing unit</b>	Hot-water boiler for coffee	s
	Steam boiler	o
<b>Milk systems and cooling units</b>	Milk Smart (MS)	o
	Side cooling unit (BKE)	o
	Centre Milk (CM)	o
	Under-machine cooling unit (UKE)	o
<b>Powder system</b>	Topping (1× Topping powder), e.g. milk powder	o
	Choco (1× Choco powder)	o
	Choco/Topping (1× Choco powder and 1× Topping powder)	o
	Twin Topping (2× Topping powder)	o
	Twin Choco (2× Choco powder)	o
	Instant powder	o
<b>General options</b>	Brewing accelerator	o
	Under-counter grounds disposal	o
	Lighting	s
<b>Payment systems</b>	Payment systems (MDB-S / DIVA2 / DIVA light)	x
	Coin and token tester	x
	Coin changer	x
<b>Colour</b>	Titanium silver	s
<b>Dimensions and weight</b>	Width (mm)	344
	Depth (mm)	538
	Height (mm)	560
	Weight (kg) (net)	25
<b>Electrical connection</b>	1L, N, PE: 220–240 V- 50/60 Hz	2000–2400 W 10–16 A 3×0,75 mm <sup>2</sup> or 3×1 mm <sup>2</sup>
<b>Water supply</b>	Internal drinking water tank	s
	Mains water supply	o
	External drinking water and waste water tanks are monitored	o
	Waste water tank is monitored	o
	Aquachange	s

s standard  
o option  
x available

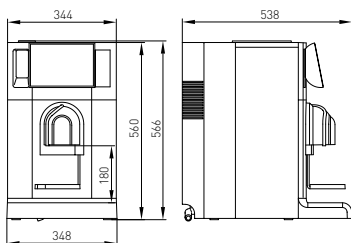

Schaerer Coffee Prime

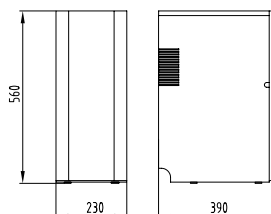
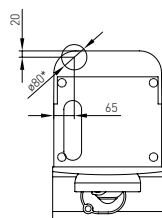

Side cooling unit

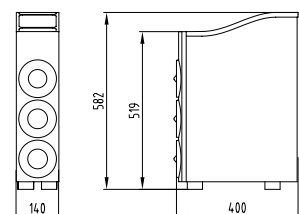

Cup dispenser



## Headquarters

### **Schaerer Ltd.**

Allmendweg 8  
4528 Zuchwil  
Switzerland  
info@schaerer.com

## Subsidiaries

### **Schaerer USA Corporation**

2900 Orange Avenue, Suite 102  
Signal Hill, CA 90755  
USA  
info@schaererusa.com

### **Schaerer Deutschland GmbH**

Siechenlach 1  
89173 Lonsee-Urspring  
Germany  
info@schaerer-gmbh.de  
www.schaerer-gmbh.de

### **Schaerer Benelux–Guy van Bogaert**

Boomsesteenweg 608  
2610 Wilrijk-Antwerpen  
Belgium  
info@schaerer.be

[www.schaerer.com](http://www.schaerer.com)